



Energy Harvesting-Enabled Self-Powered Internet of Things Systems: A Comprehensive Review of Multi-Source Architectures and Ultra-Low-Power Integration

M.D.R. Weerasuriya, *P. M. K. Alahakoon

Department of Electrical, Electronic and Systems Engineering
Faculty of Engineering, NSBM Green University, Sri Lanka

*mahinda.a@nsbm.ac.lk

Received: 10 February 2026; Revised: 27 February 2026; Accepted: 25 March 2026; Available online: 10 April 2026

Abstract: The rapid expansion of the Internet of Things (IoT) has created a strong demand for sustainable, reliable, and maintenance-free power sources for distributed sensor nodes. Traditional battery-powered IoT systems suffer from limited lifetime, frequent replacement requirements, high maintenance costs, scalability limitations, and environmental concerns. Energy harvesting provides an attractive alternative by converting ambient sources such as mechanical vibrations, thermal gradients, and radiofrequency (RF) signals into usable electrical energy. This paper reviews key energy harvesting methods for self-powered IoT devices, including vibration-based, thermal, and RF harvesting, and discusses their operating principles, limitations, and application suitability. Since no single source can provide continuous power reliably under all conditions, multi-source and hybrid harvesting architectures are examined to improve reliability and energy availability. The review also highlights power management strategies, energy storage, and integration with ultra-low-power electronics as critical factors for autonomous operation. Adaptive duty-cycling, efficient power management, and co-design of harvesters and electronics are identified as essential for synchronizing device operation with fluctuating harvested energy. These approaches are key enablers for scalable and sustainable future IoT systems.

Keywords: Ambient Energy Harvesting, Hybrid Energy Harvesting Systems, Internet of Things (IoT), Multi-Source Architectures, Ultra-Low-Power Electronics.

1 INTRODUCTION

The Internet of Things (IoT) concept has initiated a big wave of change by allowing extensive linkages among sensors, actuators, and microcontrollers in a wide range of sectors such as smart cities, industrial monitoring, healthcare, agriculture, transportation, and environmental sensing [1],[2],[3]. The studies we looked at point to significant growth in the number of installed IoT units, resulting from the requirement for ongoing data collection and internet access in both indoors and outdoors [1],[2]. Such a large-scale installation has resulted in the need for reliable and sustainable power sources for IoT components, in particular, for wireless sensor nodes that are frequently scattered in remote or inaccessible areas [1],[3].

Legacy battery-driven IoT solutions encounter intrinsic problems that severely limit their ability to scale and operate over an extended period. The studies we examined pinpoint short battery life, a need for battery replacement, and maintenance-related costs as the most serious barriers to scaling IoT deployments [1],[2],[3]. Devices in areas like industrial infrastructure monitoring, environmental sensing, and healthcare wearables are rarely accessible physically for battery replacement, and this results in loss of system reliability and increased operational overhead [1],[2]. On top of that, the environmental issues involved in battery disposal and replacement have also been pointed out as a concern, particularly as IoT deployments scale to billions of devices [2],[3].

To tackle these problems, the existing literature points out that fully autonomous and zero-maintenance IoT with energy harvesting technologies is a way forward [1],[3]. Energy harvesting enables an IoT device to transform the energy of the surrounding environment, such as mechanical vibrations, thermal gradients, and RF signals, into electrical power that can be used, thus reducing the reliance on or completely doing away with the use of conventional batteries [1],[3].

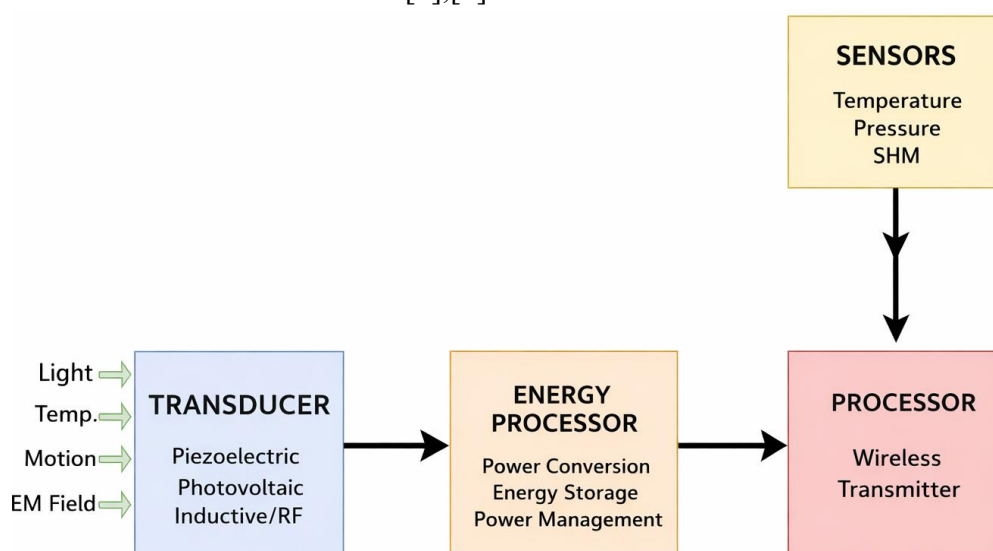

Fig. 1. A workflow of energy harvesting [2]

Fig. 1 depicts a self-powered wireless sensing system that harvests ambient energy sources, such as light, thermal, mechanical, and electromagnetic, through a multifunctional transducer and controls the energy flow through power conversion, storage, and management for reliable operation [2]. The supplied energy power a sensing unit and a wireless-enabled processor for data acquisition and transmission. This illustration is important since it shows the combination of energy harvesting with low-power sensing and communication, thereby proving that autonomous, maintenance-free monitoring systems are possible.

In comparison to battery-based designs, self-powered IoT systems can operate for a long time without human intervention due to their lower maintenance requirements [2]. Some of the reasons behind their development are issues of scalability, power supply, and sustainability, which have resulted in efficient energy harvesting, ultra-power-saving electronics, and power management for adaptability to energy variability being the main focus of the research [1], [2], [3].

Most of the reviews so far have mainly covered separate energy harvesting methods, with very few discussing multi-source architectures and the integration of system-level ultra-low-power electronics. This paper intends to fill this void by first presenting an in-depth review of hybrid energy harvesting and then, co-design strategies of IoT systems.

1.1 Challenges in Self-Powered IoT Systems

Self-powered IoT systems that rely on energy harvesting are likely to encounter significant technical and system-level problems because of the changing nature of ambient energy sources, hardware limitations, and the generally high-power requirements of IoT devices and communication systems [4],[5],[6]. The energy harvesting is naturally discontinuous and largely dependent on the environment, since the availability of sources like sunlight, heat differences, mechanical vibrations, and RF signals keeps on changing with time and surroundings, thus resulting in an essentially random pattern of power supply at the IoT node [5],[6]. Besides, the changes in power availability at the node level will have an impact on the amount of energy that can be stored and used for the device operation over time. This will limit the potential for continuous, uninterrupted operation, which is the aim of such devices in most cases [4]. Therefore, these IoT device functions, such as sensing, processing, and communication, will have to be adjusted in real-time according to the energy available at the moment [5].

1.2 Scope and Contributions of This Review

This paper discusses the use of environmental energy harvesting, such as vibration, heat, and RF signals, to power IoT devices autonomously [1], [4], [5]. It also explores some system-level issues, including the variability of power sources, problems with making energy models and forecasting, limited energy storage capacity, and the complexity of combining multiple sources [4], [5], [6]. Reliability, scalability, and lifetime are heavily influenced by these factors, since harvested energy has to be enough to continuously power sensing, processing, and communication operations [1], [2], [5], [6].

The paper, by comparing and analyzing previous works, helps in uncovering common limitations, trade-offs, and system requirements for self-powered IoT [1], [4], [6]. Besides, it looks at the viewpoint of harvesting equipment, energy storage, and communication methods, pointing out how their conjunction determines autonomy [2], [5]. Rather than focusing on just battery-life prolongation, the paper deals with real self-powered operation and hence makes it clear when harvesting is the main energy source [1], [3], [6].

2 CLASSIFICATION OF ENERGY HARVESTING SOURCES FOR IOT

Energy harvesting (EH) makes it possible for IoT devices to work without being connected to the power grid or being regularly maintained by producing electricity from surrounding sources of energy [7]. Different approaches are solar thermal, RF, and mechanical, of which vibration, as a mechanical way of energy harvesting, has been getting the most attention because it is present in a wide range of industrial and human environments [8],[9]. Besides, vibrations generated by machinery, vehicles, buildings, and human movements offer a constant energy supply, and so, they are great methods to power widely spread IoT sensor nodes [7], [8].

2.1 Vibration-Based Energy Harvesting

2.1.1 Principle of Operation

Vibration-based energy harvesting means converting ambient vibrations into electrical power by using inertial systems. These inertial systems utilize the movement of a proof mass to generate energy that can be transferred through strain or electromagnetic induction [7]. Since actual vibrations are random and broadband, the performance of the systems is highly dependent on the frequency matching, and when there is a mismatch, the efficiency is reduced drastically [7], [8].

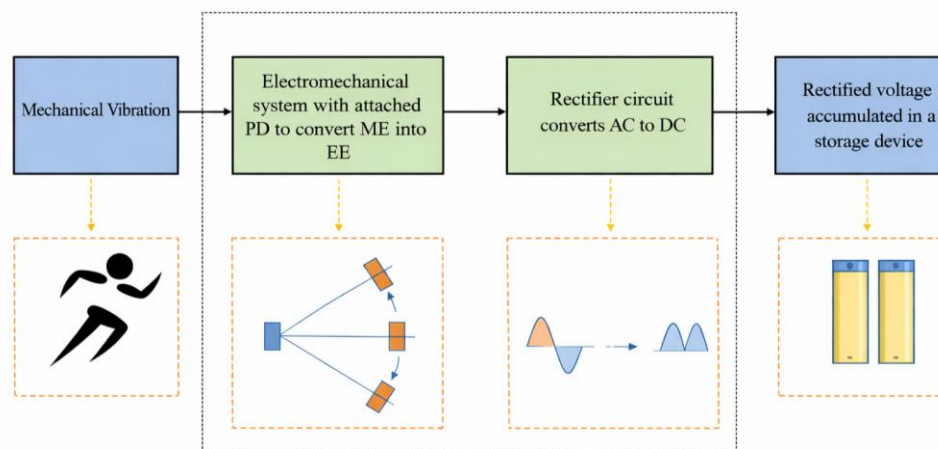

Fig. 2. Flowchart of Human Motion Energy Harvester [8]

Fig. 2 illustrates a typical vibration energy harvesting chain including transduction, rectification, and energy storage stages.

2.1.2 Classification of Vibration Energy Harvesting Mechanisms

2.1.2.1 Piezoelectric Energy Harvesting

Piezoelectric energy harvesting is based on the direct piezoelectric effect, that is, certain materials develop an electric charge when mechanically stressed. Usually, piezoelectric harvesters are fabricated as cantilever beam structures with piezoelectric layers attached, where the bending vibrations cause strain and then electrical output is generated [7],[8]. Lead zirconate titanate (PZT) and polyvinylidene fluoride (PVDF) are examples of piezoelectric materials that are largely used because of their high energy density and ability to work with very small systems.

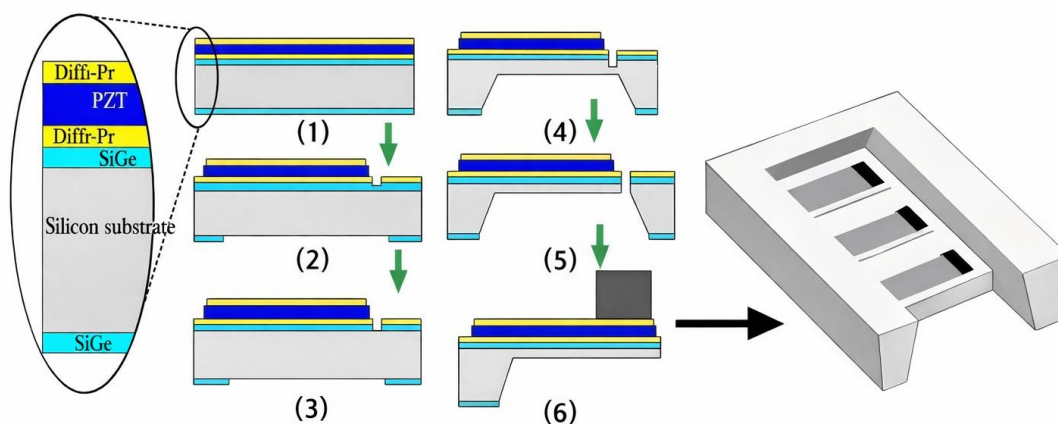

Fig. 3. Illustrates the fabrication of piezo matrix [7]

Fig. 3 shows the MEMS fabrication steps for a piezoelectric micro device with multiple layers. Essentially, piezo matrix devices thin-film stack, physically flat, made of silicon, SiGe piezoelectric, and polymer layers, are first lithographed and etched, then selectively under-etched to free the suspended structures and form the mechanically flexible cavities [7]. Then, the structural and functional layout of the device is completed by deposition steps [7]. This number is essential since it shows that microfabrication can enable small-sized piezoelectric harvesters with high voltage output, structurally simple, and in MEMS-based sensing and actuation systems. Their performance is, however, compromised by a low

resonant bandwidth, fragility of the material, and fatigue from sustained cyclic loading [7], [8].

2.1.2.2 Electromagnetic Energy Harvesting

The utilization of electromagnetic energy is based on the law of Faraday, which states that in the case of a relative movement of a magnetic field and a coil, a current is generated. As is the case with vibration harvesters, a magnet or coil is then set into motion based on the vibrations of the surroundings, which leads to the generation of electricity [8]. These types of harvesters are capable of producing more currents, and also their longevity is quite good. A miniaturized design combining a copper coil and ferromagnetic yoke, to form a magnetic path that could produce an electromagnetic force. Further, the electromagnetic generator is shown in Fig.4.

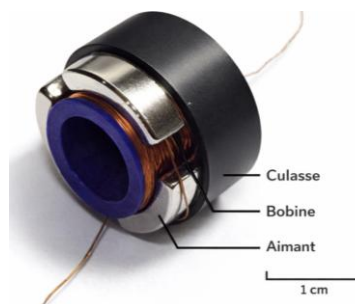

Fig. 4. Electromagnetic Generator [8]

A permanent magnet located beside the coil produces the static magnetic field required for actuation or sensing [8]. On the other hand, these devices are relatively larger and heavier, need very accurate alignment to function properly, and are barely scalable for extreme miniaturization. In fact, these factors limit their application in ultra-compact IoT sensor nodes [8].

2.1.2.3 Electrostatic Energy Harvesting

Electrostatic vibration energy harvesters work through variable capacitors, such that the change in the capacitance of electrodes due to mechanical vibrations produces electrical energy when there is an initial bias voltage or a pre-charged capacitor [7]. Being fabricable with MEMS processes and not requiring smart materials, electrostatic harvesters are very compatible with these fabrication processes.

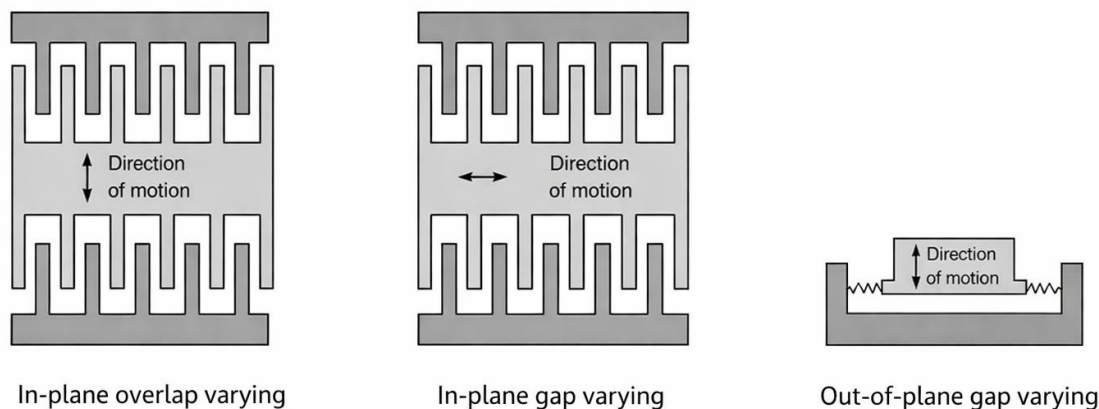

Fig. 5. Three configurations for electrostatic generators [8]

Fig. 5 shows three forms of capacitive MEMS displacement sensing. The first design allows large displacement, while gap-based designs are more sensitive [8].

These designs constitute fundamental strategies in capacitive MEMS sensing, and each of them is

tailored to a certain direction of movement and to the level of sensitivity required [8]. However, their reliance on external bias, energy inefficiency, and the fact that they are affected by mechanical damping pose challenges for their use in self-powered IoT systems [7], [8].

2.1.2.4 Relevance to IoT Applications

Several applications of vibration-based energy harvesting might be considered among IoT applications, such as industrial monitoring, structural health monitoring, transportation systems, and wearable devices, as all these applications naturally have vibrations [8]. Battery use is minimized or completely eliminated by vibration energy harvesters that, as a result, not only offer longer device lifetime but also contribute to reduced maintenance costs and lower electronic waste, which are all together in line with the sustainability objectives of next generation IoT ecosystems [8],[9].

2.2 Thermal Energy Harvesting

Thermal energy harvesting means transforming heat or temperature differences into electrical energy that can be used. In IoT setups, it is a great idea to tap into thermal energy since heat is everywhere, such as waste heat in industrial processes, electronic devices, nature, and the human body. Therefore, it is different from solar or mechanical sources that can be absent. Besides, thermal energy harvesting can serve as an everlasting source of energy for the IoT devices [10]. Therefore, thermal energy harvesting is well-suited for low-power and ultra-low-power IoT sensor nodes because the devices that produce the microwatt-level energy are able to extend the lifetime of the device really well and can even do away with the need for batteries at most [11],[12].

2.2.1 Sources of Thermal Energy for IoT

Thermal energy sources that are appropriate for IoT devices are primarily ambient heat and waste heat, as a quick summary that has been in Table 1.

Table 1. Common Thermal Energy Sources for IoT Applications [10,11]

Thermal energy source	Typical origin	Characteristics	IoT application examples
Human body heat	Skin-ambient temperature difference	Low temperature gradient (1-10 °C), continuous	Wearable sensors, health monitoring
Industrial waste heat	Machinery, motors, exhausts	Moderate to high temperature gradient	Industrial IoT, predictive maintenance
Electronic device heat	Processors, power electronics	Localized heat generation	Embedded systems, edge devices
Environmental heat	Day-night temperature variation, geothermal	Slow temporal variation	Environmental monitoring
Solar-induced heat	Heated surfaces	Indirect solar harvesting	Outdoor IoT nodes

2.2.2 Thermal Energy Harvesting Mechanisms

Thermal energy harvesting mechanisms are categorized according to the physical phenomena that are employed in the transformation of heat into electricity. The main energy aggregation types examined

include thermoelectric, pyroelectric, thermo magnetic, and thermoelastic energy harvesting [10].

a) Thermoelectric Energy Harvesting

Thermoelectric energy harvesting is a process that exploits the Seebeck effect to turn temperature differences into voltage. TEGs are based on p-type and n-type semiconductor materials, which lead to the production of DC electricity as charge carriers move from the warm to the cold areas [10], [11].

TEGs are highly reliable, operate silently, and have a long lifespan because there are no moving parts in them. However, their efficiency is quite low and generally stands within 1%-10% range for the low-grade temperature gradients that are typical of the environments where IoT devices are present [10],[12].

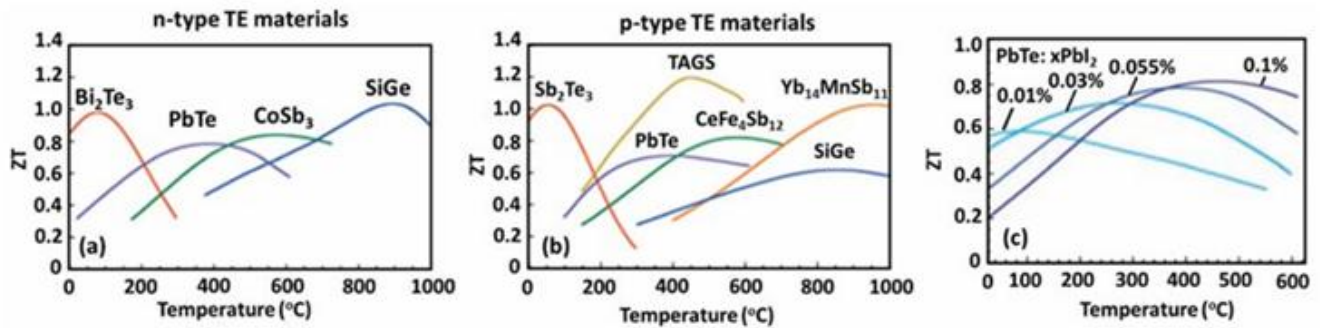

Fig. 6. Temperature dependence of the thermoelectric figure of merit (ZT) for (a) n-type and (b) p-type materials, and (c) compositional variation in PbTe-based alloys, illustrating optimal operating temperature ranges and the effect of alloying on thermoelectric performance [10].

Fig. 6 illustrates the dependence of ZT on temperature for different n-type and p-type thermoelectric materials. Bi₂Te₃ and Sb₂Te₃ suit low temperatures, PbTe and CoSb₃ intermediate, and SiGe high. PbTe alloys enable ZT improvement and peak shift, emphasizing material optimization.

b) Pyroelectric Energy Harvesting

Pyroelectric energy harvesting uses the pyroelectric effect, which is the basis for certain polar materials to produce an electrical charge when the temperature changes with time, rather than with space (temperature gradients). In contrast to thermoelectric harvesters, pyroelectric devices need cyclic heating and cooling to produce alternating current.

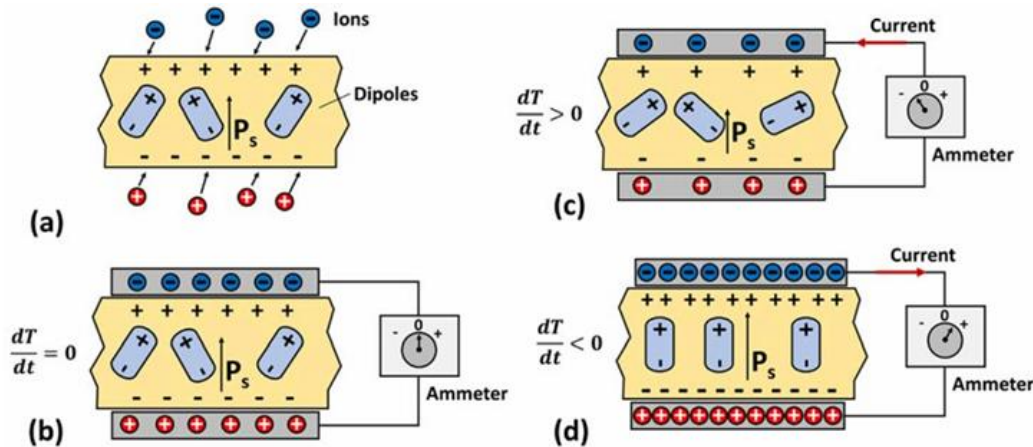

Fig. 7. Conceptual model of a pyroelectric generator [10]

According to Fig. 7, (a) Pyroelectric materials have dipole moments that are aligned, which lead to spontaneous polarization. (b) When a pyroelectric material is situated in a capacitor formed by two conductive electrodes and kept under isothermal conditions, no current is generated at steady state. (c) A rise in temperature leads to a decline in spontaneous polarization, whereas a fall in temperature leads to an

increase. Therefore, the pyroelectric materials subjected to cyclic changes in temperature generate an alternating electrical response. They suit environments with periodic temperature changes, such as intermittent heating [10],[12]. However, they require temperature variation and exhibit lower power density than thermoelectric systems under typical IoT conditions [10].

c) Thermomagnetic Energy Harvesting

Thermomagnetic energy harvesting is a method of generating power from the alteration of magnetic properties in some materials caused by the changing temperature, especially near their Curie temperature. The magnetization is changed by heating and cooling cycles that can be converted into electrical energy by electromagnetic induction [10].

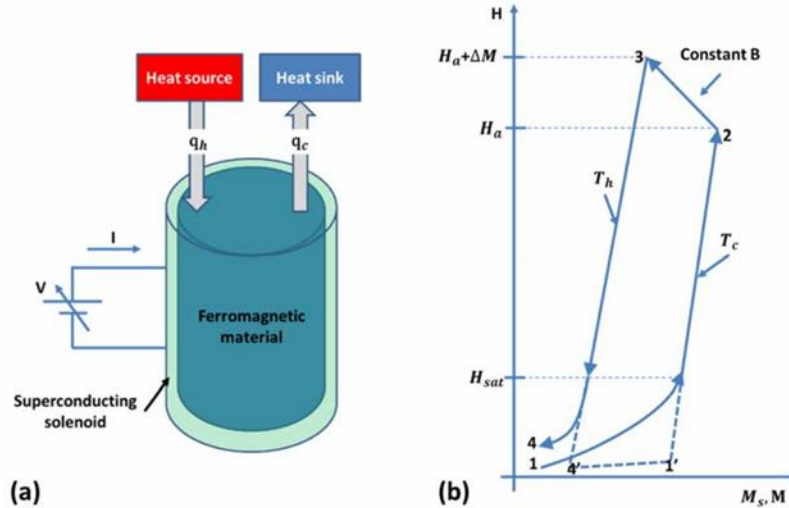

Fig. 8. (a) A conceptual model of Solomon’s thermomagnetic generator. (b) Thermomagnetic cycle [10]

As shown in Fig.8, (a) A conceptual model of Solomon’s thermomagnetic generator. (b) The thermomagnetic cycle of a concept on ferromagnetic material in a superconducting solenoid. Despite the fact that thermomagnetic harvesters are capable of working at low temperature gradients, their overall system complexity, especially the moving parts, and low power density limit their use in very small IoT devices [10].

d) Thermoelastic Energy Harvesting

Thermoelastic energy harvesting is a method of extracting energy from thermal expansion and contraction by using them to generate mechanical movement that is turned into electrical energy. This method is still mainly under research and is rarely used for IoT devices. The reason is that the devices created are low in efficiency, and also, they are mechanically complex [10].

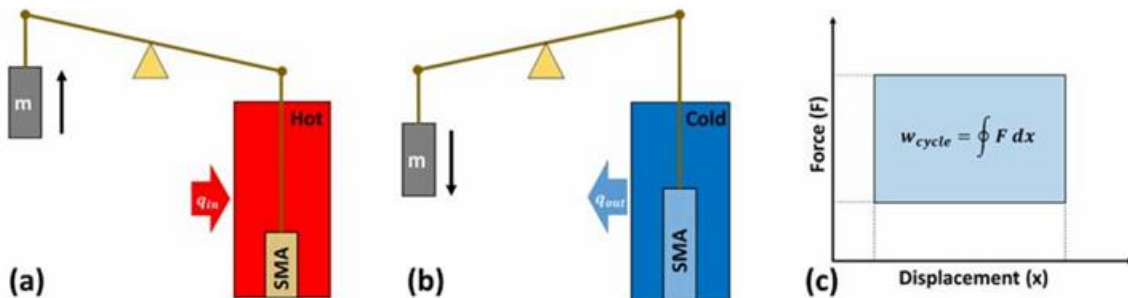

Fig. 9 Conceptual model of a thermoelastic heat engine (a) heat absorption process, (b) Heat rejection process, (c) Force-displacement cycle [10].

Fig. 9 illustrates a thermoelastic heat engine with an SMA actuator. Heat absorption (a) triggers SMA phase change, producing strain to lift the load. Heat rejection (b) restores SMA to its original state, resetting the system via mechanical bias. Cyclic thermomechanical behaviors will result in a closed force displacement loop (c), where the area enclosed by the loop is the net mechanical work produced per cycle, $w_{\text{cycle}} = \oint F dx$. This layout shows direct conversion of low-grade thermal energy into mechanical work via reversible SMA phase transformation. Table 2 compares key thermal energy harvesting mechanisms for IoT.

Table 2. Comparison of Thermal Energy Harvesting Mechanisms

Mechanism	Driving principle	Temperature requirement	Advantages	Limitations
Thermoelectric	Seebeck effect (δt)	Small to moderate gradient	Mature technology, DC output, solid-state	Low efficiency
Pyroelectric	Temperature fluctuation (dt/dt)	Cyclic heating and cooling	High voltage output	Requires temperature variation
Thermomagnetic	Temperature-dependent magnetization	Near curie temperature	Can exploit low-grade heat	Mechanical complexity
Thermoelastic	Thermal expansion	Variable	Simple concept	Very low power density

2.3 Radio-Frequency (RF) Energy Harvesting

RF energy harvesting is a way of powering battery-less wireless sensors for IoT and Industry 4.0. It is a great way to keep devices running for a long time, with minimum maintenance, and being environmentally friendly. In fact, it takes the surrounding electromagnetic waves emitted by communication sources, transforms them into DC power, and this is definitely a scalable option when compared to battery-based systems [13].

2.3.1 Principle of RF Energy Harvesting

An RF energy harvesting system consists of an antenna, a matching network, a rectifier filter, and a storage/load. It turns surrounding RF waves into DC that can be used for extremely low-power devices or for storage purposes [13], [14]. Since it works in the low-power far-field, it is a lot more difficult than solar or thermal harvesting and thus demands the most efficient circuits for the inputs below 10 dBm [13], [14].

2.3.2 RF Energy Sources and Power Availability

With the dense wireless communication infrastructure of modern cities and industrial areas, ambient RF energy is constantly present. Some of the main RF sources are GSM, LTE 5G, Wi-Fi (2.4 GHz and 5.8 GHz), digital TV broadcast (UHF band), and RFID systems. Nevertheless, as discussed in [13] and validated through experiments in [15], shown in Table 3, the power density of ambient RF signals is usually several orders of magnitude lower than that of solar or indoor lighting sources and could be as low as nW/cm^2 to $\mu W/cm^2$ levels.

Table 3. Comparison of different sources of energy (W/m²) [15]

Solar	Interior Lighting	Moon	Cell Tower	Wi-Fi
1.1x10 ³	0.5	1.0x10 ⁻³	0.1x10 ⁻³	0.01x10 ⁻³

On the other hand, RF energy harvesting has several outstanding advantages, such as it doesn't depend on lighting conditions, can run during the day and at night, and is ideal for indoors and hidden environments where solar energy is not available [13], [15].

2.3.3 Rectenna Design and Efficiency Challenges

The rectifying antenna (rectenna) is a major part of the RF energy harvesting system [13]. Most of the loss in the rectifier occurs due to the following four reasons: diode non-linearity, impedance mismatch, harmonic generation, and the use of different low power levels. At very low RF power levels, the efficiency of the traditional rectifier circuit drops drastically, requiring the usage of an efficient circuit design for performing effective conversion of RF to DC power. To tackle these issues, sophisticated methods like harmonic termination, harmonic recycling, low-pass filtering, as well as Class-F/inverse Class-F rectifier topologies were thoroughly studied [13]. The main purpose of these techniques is to reduce the harmonics that are inevitably produced by the rectification process, reconfigure the shapes of voltage and current waveforms, and, in general, increase the power conversion efficiency even when the power is at very low levels.

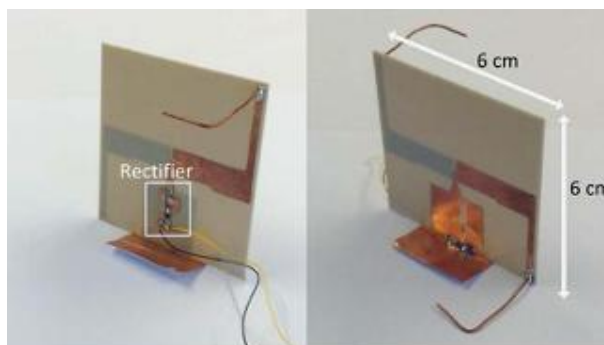

Fig. 10. Fabricated dual-band rectenna prototype [14]

Fig. 10 shows a 6 cm × 6 cm RF rectifier on a dielectric substrate with diode-based rectification. An impedance-matched PCB directs RF power to the rectifier, converting it to DC via high-frequency diodes and passive components [14]. The low-profile planar design minimizes conduction loss and enables stable operation for wireless power or RF-energy-harvesting applications [14].

2.3.4 Applications in Battery-Less IoT and Industry 4.0

RF energy harvesting is a major technology that can be used in many types of applications. For example, it can be used to create wireless sensor nodes that can operate without batteries, RFID-based sensing, Bluetooth Low Energy (BLE) tags, and industrial monitoring systems. As pointed out in previous studies, combining RF energy harvesting with ultra-low power communication technologies is the key to developing self-sustaining sensor platforms for smart manufacturing, logistics, healthcare, and structural health monitoring [13]. In addition, RF energy harvesting has an important role in cutting down on electronic waste and helping with NetZero and low-carbon strategies, which is why it is considered a strategic technology for the future Industry 4.0 and IoT ecosystems [13].

2.4 Comparative Analysis of Energy Sources

Solar gives top power in bright spots but fails in dim light. Thermoelectric runs steady with weak output, just microwatts, from heat differences [16], [17]. Table 4 shows the comparison. The thing is, neither matches IoT needs fully. Power gaps remain wide across conditions.

Table 4. Comparative Analysis of Ambient Energy Sources for IoT Applications

Energy Source	Typical Power Density	Key Advantages	Main Limitations	Suitable IoT Applications	Ref.
Solar (Photovoltaic)	$\mu\text{W-mW/cm}^2$ (indoor/outdoor)	High maturity, high power density under light, long lifetime	Strongly light-dependent, poor performance in dark or shaded environments	Outdoor sensors, indoor smart buildings, wearables	[16], [17]
Thermal (Thermoelectric)	$\mu\text{W/cm}^2$	Continuous and maintenance-free operation when temperature gradients exist	Low power output requires a stable temperature difference	Industrial monitoring, body-worn sensors	[16]
Mechanical (Piezoelectric/ Electromagnetic)	$\mu\text{W-mW/cm}^2$	Effective in vibration-rich environments, compact designs are possible	Intermittent energy availability, frequency-dependent	Machinery monitoring, transportation, and wearable devices	[16], [17]
RF Energy Harvesting	$\text{nW-}\mu\text{W/cm}^2$	Enables battery-less operation, compatible with wireless communication	Very low harvested power, distance, and source dependent	Ultra-low-power IoT nodes, passive sensors	[17], [18]

Mechanical harvesting (piezoelectric, electromagnetic) operates very well in vibration-rich areas; piezoelectric is most suitable for low-frequency applications with a small size, whereas electromagnetic can deliver higher power but is larger in size [16], [17]. However, it is a non-continuous process. RF harvesting makes battery-free operation possible but only provides very low power, which is ideal for ultra-low-power nodes [17], [18]. There is no one power source that is perfect for everyone. Solar and thermal sources are good for stable environments, whereas mechanical and RF sources are more appropriate for mobile or infrastructure-based use. Therefore, hybrid systems are the solution to improve reliability and sustainability [16], [17].

2.5 Solar Energy Harvesting

Among different options for energy sources, solar power is usually considered as one of the most effective ways of energizing low-power and autonomous electronic devices, mostly due to a relatively high level of power present in the environment and an advanced technology of photovoltaic (PV) cells [14]. As a matter of fact, solar energy is usually mentioned as one of the few ways devices equipped with sensors or the nodes for the Internet of Things (IoT) can be sustained by themselves, if combined with efficient

electric power management and hybrid energy harvesting systems [14]. In addition to that, it has been noticed that indoor light energy harvesting is a big step forward, in addition to outdoor operation, where thin-film, organic, and perovskite PV cells are preferred to be used because of their better spectral match and higher conversion efficiency under weak illumination [16]. At the same time, reliance on brightness level, sensitivity to the device's position, and insufficient output in the case of overcast or nighttime lighting still represent significant issues that have resulted in the continuation of research efforts in the area of solar energy harvesting devices [14], [16].

3 MULTI-SOURCE ENERGY HARVESTING ARCHITECTURES

Multi-source energy harvesting fuses many different ambient sources (solar, vibration, thermal, and RF) to reduce the turnaround time of energy generation and strengthen the reliability of power supply in the IoT systems [19]. By means of sharing or adaptively managing the power, it can increase the energy presence, the consistency, and the lifespan of the device. Hybrid systems can either run all sources at the same time or switch one after another, trying to find the right balance of efficiency, complexity, and robustness for long-term autonomous operation of IoT devices [19],[20],[21].

3.1 Motivation for Multi-Source Harvesting

Multi-source energy harvesting allows going beyond the limitations of single-source systems, which in turn provide power intermittency and their dependence on the environment, making them unsuitable for long-term IoT operation. Battery use becomes increasingly expensive and environmentally unsustainable with large-scale and remote deployments, leading to a strong need for local energy production [22]. Integration of solar, thermal, mechanical, and RF energy sources leads to improved continuity, reliability, and system robustness [23].

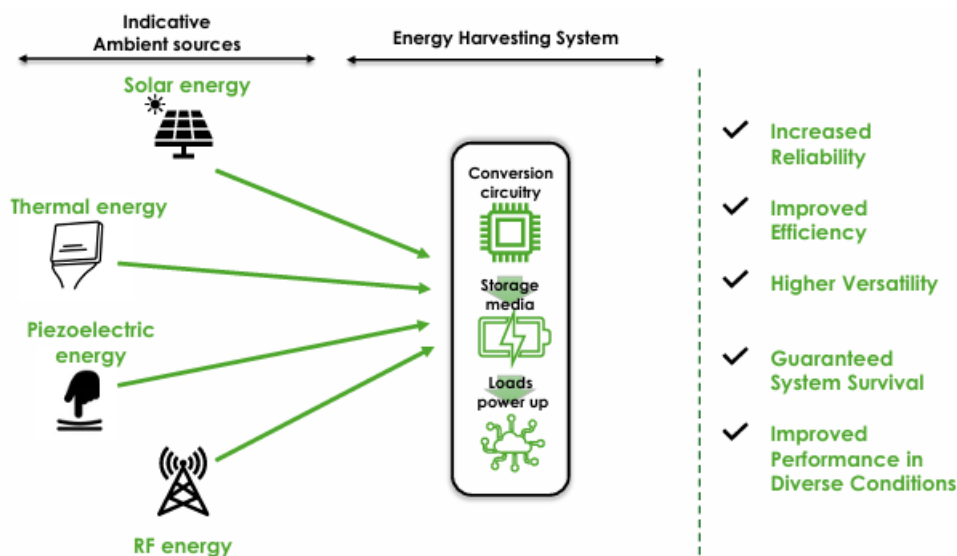

Fig. 11 Multi-source energy harvesting concept [24]

Fig. 11 shows a multi-source harvester converting solar, piezoelectric, and RF energy to electricity, with interface circuits for each source and combined energy management, ensuring efficient, reliable, and self-sustained operation [24].

Multi-source harvesting adopts adaptive power management to either merge or pick energy sources, thereby increasing the reliability, efficiency, and lifetime of the systems as compared to single-source ones

[24]. This technology allows low-power IoT devices to keep working without interruption, even though the conditions may vary, and is the main enabler to fully autonomous and maintenance-free systems [24].

3.2 Reported Hybrid Harvesting Architectures

Singh et al. [25] explain that hybrid energy harvesting systems combine several sources (solar, vibration, RF, thermal, and piezoelectric) to compensate for the intermittency and low power density in single-source harvesting systems. These systems enhance the reliability and availability of energy for IoT and Wireless Sensor Network (WSN) applications. A frequent method is to combine solar and vibration energy harvesters, with solar power being the main source of energy when there is light, and vibration being the backup source when there is low light [25]. The outputs are first rectified, then conditioned, and finally integrated through a power management unit (PMU).

A prevalent method of hybrid architecture is to merge solar energy with thermal energy harvesting. The heat sources rely on temperature differences, and solar gives a high amount of power during daylight, which helps to be less reliant on one condition only [25]. Using DC-DC converters and MPPT, the efficiency can be enhanced, as revealed in IoT applications [26]. Even more sophisticated setups can combine several sources (e.g., solar, RF, vibration) along with energy-aware control units that adjust the power supply according to the availability and the load demand [25].

Hybrid harvesting systems nowadays feature two-storage configurations in batteries and supercapacitors. In such a case, supercapacitors serve as short-term energy buffers with frequent cycles, while the batteries remain as long-term solution providers [25],[26]. The implementation of this method makes the system more robust and capable of multi-source harvesting. In general, hybrid architectures yield greater energy availability, stability, and self-sufficiency than single-source systems; their effectiveness relies heavily on efficient power management and dependable harvesting techniques [25], [26], [27].

Table 5 Reported Hybrid Energy Harvesting Architectures [28]

Hybrid Architecture	Combined Mechanisms	Key Benefit	Typical Applications
PE–EM	Piezoelectric + Electromagnetic	Higher power density and wider frequency range	Structural and industrial monitoring
PE–TE	Piezoelectric + Triboelectric	High voltage, effective at low frequencies	Wearables, healthcare sensors
EM–TE	Electromagnetic + Triboelectric	Improved low-frequency harvesting	Water-wave and wind energy
PE–EM–TE	Piezoelectric + Electromagnetic + Triboelectric	Maximum combined output	Self-powered IoT and smart infrastructure
PV–TEG	Solar + Thermal	Continuous energy under variable conditions	Wireless sensor nodes, indoor IoT

Table 5 presents a concise overview of hybrid energy harvesting setups that integrate various mechanisms in order to address the issues of intermittency and low output typical of single-source systems [28]. Among the different hybrid combinations, piezoelectric-electromagnetic and piezoelectric-triboelectric are the most widely used designs mainly because of their complementary characteristics. On the other hand, triple-hybrid systems can deliver even better results, but they are more complex and

expensive.

3.3 Power Management Strategies

Power management stands as a major touchpoint where harvested energy and IoT functionality meet. For example, in [29], the authors replace the fixed timer-based activation, which is a cause of energy wastage and power availability misalignment, with an adaptive approach. Their method physically disconnects the sensor node from the supercapacitor through the microcontroller command at the end of each cycle. This allows the operating time to be adjusted according to the energy harvested instead of being pre-determined by time [29].

At the circuit level, the paper [29] introduces a simple hysteresis-based controller using low-power components complemented with a supercap as energy storage. The controller is active only within the specified voltage range, and MΩ resistors help keep the control network current to a minimum.

Even though the experiments were done with solar, the harvester's interface can be used for solar, piezoelectric, and thermoelectric sources.

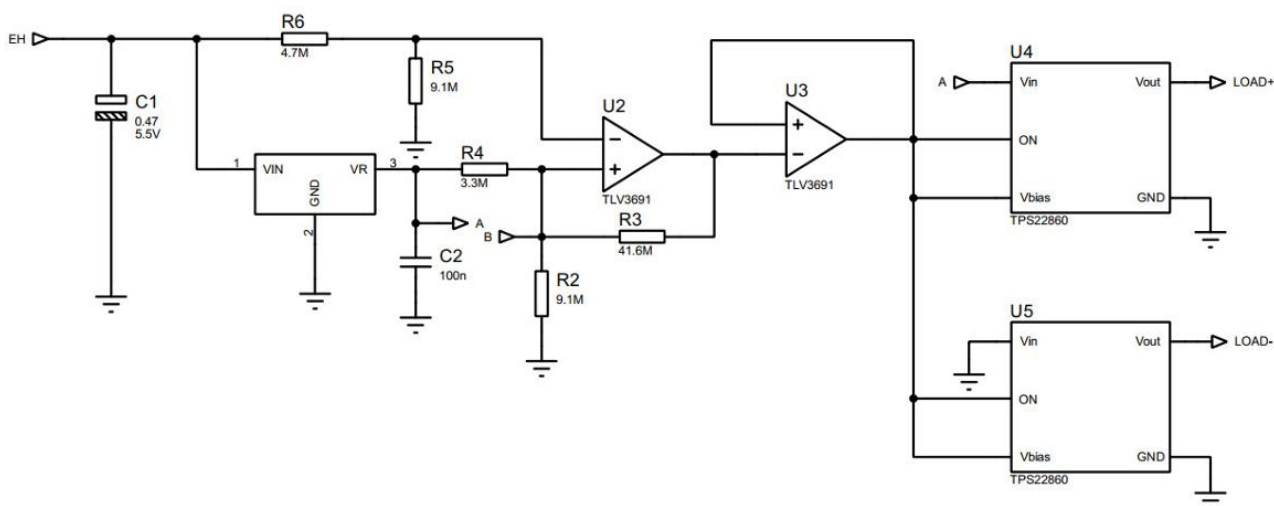

Fig. 12. Power management circuit [29]

Fig. 12 shows a hysteresis-controlled circuit for intermittent IoT operation, converting AC to DC, storing it in a 0.47 F supercapacitor, and regulating via comparator thresholds [29].

Driving TPS22860 switches, the comparator sends clean logic to a TLV3691 buffer. The MCP1700 LDO brings 3.3 V to control circuits. Energy from supercapacitors powers microcontrollers and sensors only when needed. This approach supports battery-less IoT operation [29].

Power management in hybrid harvesters is quite complicated because of the most obvious differences in the output characteristics of transducers, e.g., piezoelectric, which are associated with high-voltage/low-current and electromagnetic, with low-voltage/high-current output, so the separate conditioning, which very often leads to efficiency reduction, is required [30]. Synchronized interfaces, MPPT, and shared converters are the means of improving integration; however, there is no single universal solution [30]. At the system level, the strategies can be accessed through a new RF harvesting and the corresponding network protocols. We thus highlight three typical ways. That is, adaptive duty-cycle control [29], source-aware interface design [30], and protocol-level coordination [31].

4 INTEGRATION WITH ULTRA-LOW-POWER ELECTRONICS

System-level sizing of harvesters, storage, and loads is needed when combining energy harvesters with ultra-low-power electronics. Minimal electronics support sensing, and power models connect activity and voltage to energy use. At least in theory, this setup could work for low-power applications [32],[33].

4.1 Energy-Aware System Design

Energy-aware system design is explained by a previous study [32], as a change of the node behavior based on the availability of energy instead of operating with full functions at all times. The advice given is to accumulate energy when the source is strong, spend energy only when necessary, minimize the current in stand-by mode, and turn off the parts that are not needed. So, wireless nodes can be in normal mode as well as in low power, standby, and high power modes based on the energy balance [32].

Another way of looking at this system is highlighted by M. Babu et al [34], where total power is broken down into dynamic, static, and short-circuit parts, and coordinated low-power methods are said to be more effective than isolated optimizations [34]. Several benchmarks indicate that the choice of the processing platform considerably affects the node budget, as data-logging power values of 1.52 mW for PIC16LF, reported power consumption is 0.965 mW for MSP430FR, and 1.135 mW for STM32L [32]. Very low power support electronics, such as a 315 nW bandgap reference operating at 0.5 V supply and a 14 nW completely integrated temperature sensor at 350 mV, perfectly fit this energy-efficient integration objective [32], [33].

4.2 Co-Design of Harvesters and Electronics

The changing of converters according to the source features, availability of energy, and storage/operation is the job of co-design, whereas hybrid systems increase the reliability only if the added circuitry is energy- and cost-efficient [32]. Operating with very limited harvested energy is possible thanks to low-voltage electronics (for example, circuits working at a voltage lower than zero. 5 V, sensors consuming only a few nW, and optimized logic), which shows that the co-design must take into account both the harvesting and ultra-low-power components [33], [34].

Table 6. Reported ultra-low-power metrics relevant to integration with harvested-energy systems.

Reported item	Metric	Reported value	Ref.
PIC16LF microcontroller	Data-logging power	1.52 mW	[32]
MSP430FR microcontroller	Data-logging power	0.965 mW	[32]
STM32L microcontroller	Data-logging power	1.135 mW	[32]
Passive-front-end receiver	wake-up Power consumption	1.2 μ W	[32]
Passive-front-end receiver	wake-up Minimum input power for successful detection	-55 dBm	[32]
Tuned-RF receiver	duty-cycled wake-up Power consumption	3 μ W	[32]
Tuned-RF receiver	duty-cycled wake-up Sensitivity	-90 dBm	[32]
CMOS bandgap voltage reference	Supply/power	0.5 v / 315 nW	[33]
Fully integrated temperature sensor	Supply/power	350 mv / 14 nW	[33]

Current-mode SoftMax circuit	Supply/power	0.5 v / 3 μ W	[33]
Self-adaptive address decoder (mixed mode)	Energy reduction/speed reduction	28% / 8.7%	[33]
Self-adaptive address decoder (fully static mode)	Additional energy saving	29%	[33]

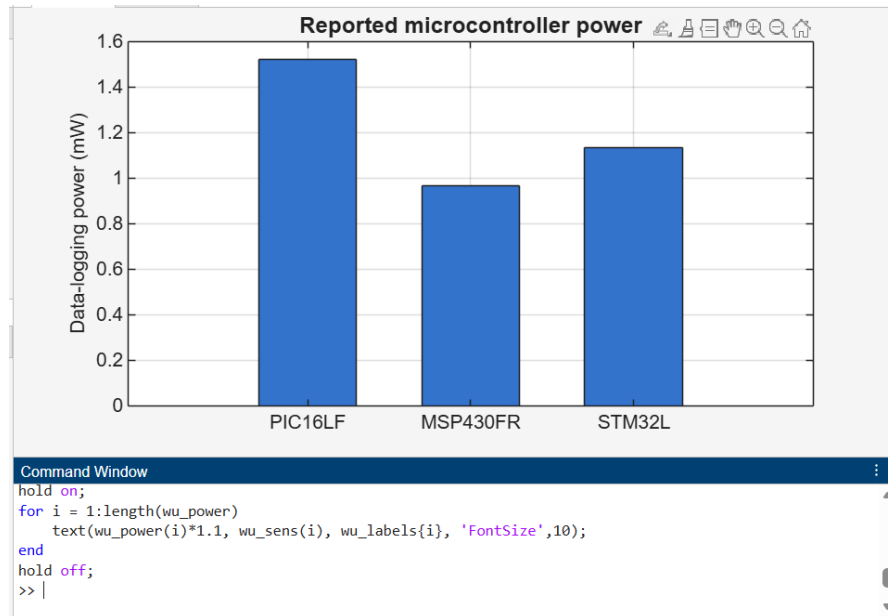

Fig. 13. Reported integration-relevant trade-offs from (left) data-logging power of three low-power microcontrollers [32], graph generated by MATLAB.

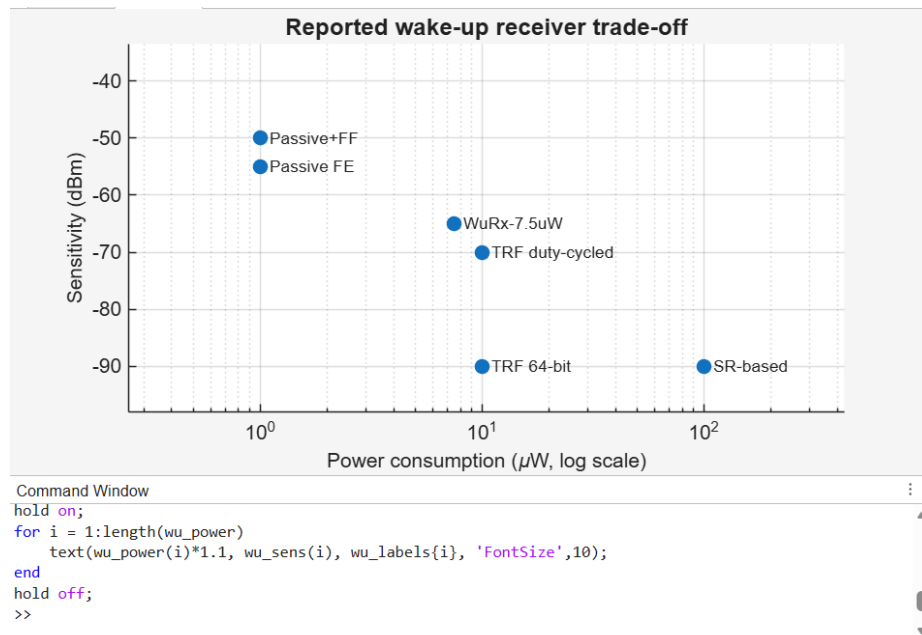

Fig. 14. Reported wake-up receiver power sensitivity points [32], graph generated by MATLAB.

Fig. 13 and 14 show that modern microcontrollers (~1-1.5 mW) exceed ambient harvester output, requiring cycling and power gating. Wake-up receivers trade low power (~1-10 μ W) for sensitivity (~-

90 dBm), prompting supercapacitors, hysteresis management, and event-driven wakeups [32].

5 PERFORMANCE COMPARISON AND DISCUSSION

5.1 Reported Performance Metrics

System-level performance studies compare a variety of energy harvesting techniques (vibration, thermoelectric, photovoltaic, magnetic) aimed at powering Internet of Things (IoT) sensor nodes over an extensive range of power levels [32],[35]. Ensuring reliable operation calls for adaptive energy management, efficient communication, and the use of different low-power modes. Therefore, performance is a function of integrated harvesting, storage, and load characteristics [32].

Table 7. Performance-related dimensions [32]

Reported performance-related dimensions	Observations
Harvesting-source coverage	Vibration, thermoelectric (temperature gradients), photovoltaic, and magnetic-field energy harvesting have been discussed.
Reported performance framing	The sources are claimed to provide different power levels suitable for wireless sensor nodes.
Storage coupling	Batteries and supercapacitors are the two main energy storage options for ambient energy harvesting systems.
System-level control metric	Adaptive management continuously adjusts harvested and required energy to ensure optimal operation conditions at all times.
Communication-aware optimization	The main issues identified are communication/transmission procedures and frequencies, sleep mode, and energy-efficient algorithms.

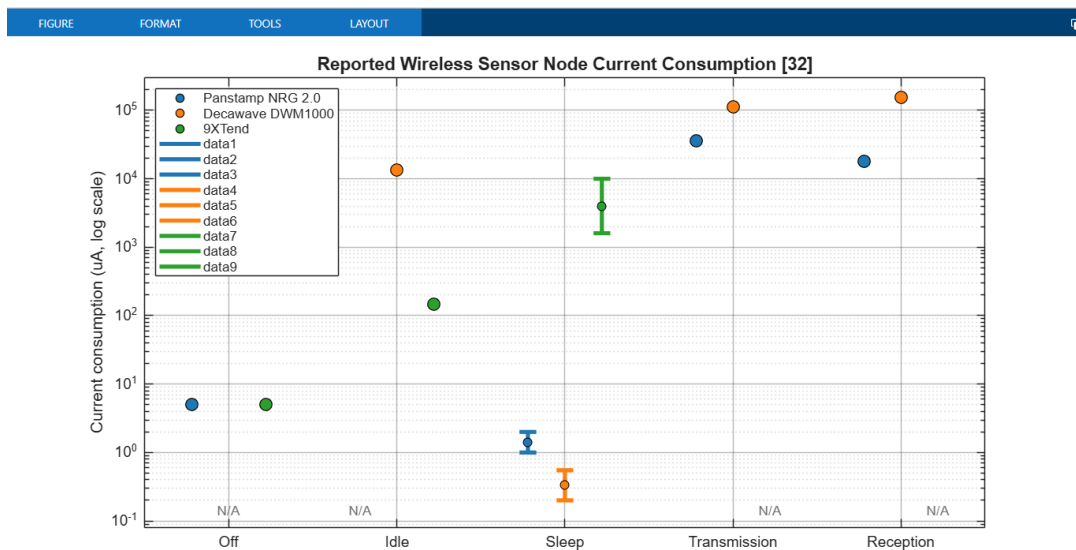

Fig. 15. Wireless sensor node current consumptions [32]

Fig. 15 shows the current consumption of three wireless sensor nodes across operating states, highlighting large differences. Low-power sleep modes and duty-cycling are critical for energy-constrained IoT systems.

5.2 Strengths and Limitations

Instead of focusing on the harvester alone, it connects ambient sources, storage units, and wireless-node operation, thus presenting performance as a relationship between the amount of harvested energy and the system's energy demand [32]. This is of technical significance since studies consider hybrid sources that combine energy harvesting systems with batteries or supercapacitors as a way to achieve autonomous wireless sensor nodes [32]. What is more, it is not merely limited to superordinate optimization to transducer only; the explicit inclusion of adaptive energy management, communication and transmission optimization, sleep mode, and energy-efficient algorithms broadens the discussion from component-level conversion to node-level autonomy [32]. So, this becomes a really useful tool for measuring energy-aware design and not only isolated harvesting mechanisms [32].

The main limitation is that ambient energy harvesting systems are still not reliable enough to power all kinds of electronic applications [32]. Hence, the hybridization with batteries or supercapacitors is a must where ambient energy can't stand on its own [32]. In the context of the extracted discussions, most focused on system-level design guidance, while the comparative evidence explicitly shown here is still qualitative rather than numerically tabulated [32].

5.3 Application Suitability Analysis

Previous authors have pointed out that it fits most directly with autonomous wireless sensor nodes that are part of IoT scenarios [36]. Its practical use is based on two direct observations. First, the reviewed harvesters represent a very wide range of power levels. Second, the correct operation will require a balance between the energy harvested and the energy needed at different times [32]. In this way, it can be a great design source for sensor nodes that are required to optimize energy consumption along with their communication behavior [36]. Suitability evaluations also show that relying on a single ambient source for energy harvesting may not be sufficient to power certain electronic devices. On the contrary, hybrid systems that combine energy harvesters and batteries or supercapacitors provide a better way to achieve complete independence [37]. Therefore, applications should be designed, such as energy supply, energy storage, and low-power operational methods, which are co-designed at the node level [37],[38].

6 CHALLENGES AND FUTURE RESEARCH DIRECTIONS

6.1 Technical Challenges

The main technical problem is that the amount of energy that can be harvested is extremely variable and often not enough. In wireless sensor systems powered solely by ambient energy harvesting, the energy supply is mostly spotty rather than continuous, which makes the sensor nodes operate only for a short time before recharging; that is, they go through cycles of operating and recharging [39]. Along this line, recent sustainable electronics literature also points out that a single-source harvester can hardly be relied on to produce stable output, while low power densities, intermittent availability of the source, and conversion losses of the transducer and power management stages are still the major limiting factors for the practical self-powered operation of the Internet of Things [40].

The hardware chain linking the power harvester to the load represents the second major challenge. One article that highlighted this point was a comprehensive review and survey of wireless power transfer technologies [39]. Another article is a recent critical review of energy harvesting technologies, which is very well indexed and also highlights the various limitations of energy harvesters [40]. Also, the more

environmentally friendly sustainable material platforms and printed devices are typically characterized by lower average conversion efficiency and shorter operational lifetime compared to their conventional material counterparts, on top of which the RF, thermal, and mechanical harvesters each have their own source-specific bottlenecks like weak ambient RF power, small thermal gradients, and inability to endure repeated deformation, respectively [40].

6.2 System-Level Challenges

Energy harvesting changes the very nature of the design objective at the system level, according to the literature. Instead of conserving a fixed battery budget, the aim is to maximize the utilization of the currently available harvested energy [39]. This makes it difficult to implement protocol timing, duty cycling, and data delivery because the node wake-up schedules cannot be accurately forecasted since recharge time depends on environmental conditions; consequently, traditional backoff, retransmission, and synchronization mechanisms might turn out inefficient or even harmful in cases of extreme energy scarcity [39].

System integration is made even more complex by the interrelation between source properties, storage units, power management, communication protocols, and application demands [39], [40]. The research highlights that low-power wireless protocols and duty-cycled operation are usually required as communication accounts for most of the IoT energy consumption, while high-throughput protocols generally go beyond the steady output of ambient micro-scale harvesters unless storage is involved [40]. Moreover, middleware and adaptive control remain challenging because neighboring nodes may not share synchronized operating conditions, and learned or stored state information can be lost when energy is depleted [39].

6.3 Future Research Opportunities

There are several research directions. First, future work should improve the performance of sustainable energy harvesting systems through higher-power-density transducers, storage elements with higher energy density, lower cold-start PMUs, more effective MPPT schemes, and higher-efficiency AC/DC and DC/DC conversion stages [40]. Second, better modeling and empirical validation are still needed, since there is no single general model that has been shown to fit all harvesting scenarios, and the accuracy of scenario-dependent stochastic models requires further validation across different sources and environments [39].

One more is a hybrid and reconfigurable system. The recent sustainable electronics perspective points to hybrid energy harvesting as an effective way to increase reliability in changing ambient conditions, whereas reconfigurable electronics could enable features like dynamic power management, adaptive signal processing, and also more efficient energy distribution [40]. In parallel, the earlier wireless-sensor-network study points to opportunities in new protocol designs, bio-inspired or learning-based adaptation, and middleware mechanisms that explicitly account for intermittent power and unsynchronized node activity [39].

7 CONCLUSION

The paper presents an overview of ambient energy harvesting technology as a major driver for creating self-powered, maintenance-free IoT devices. As IoT applications continue to grow in various fields, the drawbacks of battery-operated gadgets, such as limited lifetime, high maintenance costs, and negative effects on the environment, highlight the need for alternative options. Utilizing energy from sources like

vibration, thermal differences, and RF signals can enable the independent functioning of remote sensor nodes, although each source comes with a different set of pros and cons. Since energy obtained from harvesters is generally very low, sporadic, and varies with environmental conditions, for effective working, the system should have efficient energy storage and power management techniques combined with ultra-low-power electronic devices.

The major revelation is that overall system design is more important than the performance of any single harvester. In fact, the reliable working of a harvester depends not only on the complementary design of energy transduction, storage, power management sections, and communication, but also on the strategies such as adaptive duty cycling, hysteresis control, and event-driven operation, which align the devices' activities with the available energy. Multi-source hybrid systems can be used to increase the energy supply and make the system more robust, but the level of complexity and number of design trade-offs are also increased. In general, although the issues of low power density, conversion losses, and intermittent operation remain, the improvements in transducers, energy storage, power management, and energy-aware control are necessary for the realization of scalable and autonomous IoT platforms.

REFERENCES

- [1] B. G. Reddy, "Powering the Internet of Things: Advances in energy harvesting technologies," *International Journal of Scientific Research in Computer Science, Engineering and Information Technology*, vol. 11, no. 1, pp. 1867-1876, Jan.-Feb. 2025, [doi:10.32628/CSEIT251112192](https://doi.org/10.32628/CSEIT251112192).
- [2] P. Kamalinejad, C. Mahapatra, Z. Sheng, S. Mirabbasi, V. C. M. Leung, and Y. L. Guan, "Wireless energy harvesting for Internet of Things," *IEEE Communications Magazine*, vol. 53, no. 6, pp. 102-108, Jun. 2015, [doi:10.1109/MCOM.2015.7120024](https://doi.org/10.1109/MCOM.2015.7120024).
- [3] H. Elahi, K. Munir, M. Eugeni, and P. Gaudenzi, "Energy harvesting towards self-powered IoT devices," *Energies*, vol. 13, no. 21, art. no. 5528, 2020, [doi: 10.3390/en13215528](https://doi.org/10.3390/en13215528).
- [4] B. G. Reddy, "Powering the Internet of Things: Advances in energy harvesting technologies," *International Journal of Scientific Research in Computer Science, Engineering and Information Technology*, [doi: 10.32628/CSEIT251112192](https://doi.org/10.32628/CSEIT251112192).
- [5] T. Sanislav, G. D. Mois, S. Zeadally, and S. C. Folea, "Energy harvesting techniques for Internet of Things," *IEEE Access*, vol. 9, pp. 39530-39549, 2021, [doi:10.1109/ACCESS.2021.3064066](https://doi.org/10.1109/ACCESS.2021.3064066).
- [6] P. Kamalinejad, C. Mahapatra, Z. Sheng, S. Mirabbasi, V. C. M. Leung and Y. L. Guan, "Wireless energy harvesting for the Internet of Things," *IEEE Communications Magazine*, vol. 53, no. 6, pp. 102-108, June 2015, [doi: 10.1109/MCOM.2015.7120024](https://doi.org/10.1109/MCOM.2015.7120024).
- [7] R. Sikka and M. Ojha, "An in-depth look into vibration energy harvesting: Modeling and implementation," *International Journal of Innovative Research in Computer Science and Technology*, vol. 9, no. 6, pp. 148-152, Nov. 2021, [doi:10.55524/ijirest.2021.9.6.34](https://doi.org/10.55524/ijirest.2021.9.6.34).
- [8] Mohanty, S. Parida, R. K. Behera, and T. Roy, "Vibration energy harvesting: A review," *Journal of Advanced Dielectrics*, vol. 9, no. 4, Art. no. 1930001, 2019, [doi:10.1142/S2010135X19300019](https://doi.org/10.1142/S2010135X19300019).
- [9] S. Gomez-Gijon, F. J. Romero, V. Tora-López, and A. Rivadeneyra, "Energy harvesting for sustainable electronics: Challenges and opportunities," *MRS Communications*, 2025, [doi:10.1557/s43579-025-00892-w](https://doi.org/10.1557/s43579-025-00892-w).
- [10] R. A. Kishore and S. Priya, "A review on low-grade thermal energy harvesting: Materials, methods and devices," *Materials*, vol. 11, art. no. 1433, 2018, [doi: 10.3390/ma11081433](https://doi.org/10.3390/ma11081433).
- [11] A. Proto, D. Bibbo, M. Cerny, D. Vala, V. Kasik, L. Peter, S. Conforto, M. Schmid, and M. Penhaker, "Thermal energy harvesting on the bodily surfaces of arms and legs through a wearable thermo-electric generator," *Sensors*, vol. 18, art. no. 1927, 2018, [doi: 10.3390/s18061927](https://doi.org/10.3390/s18061927).
- [12] A. Ali, H. Shaukat, W. A. Altabey, H. Elahi, S. A. Kouritem, S. Taimur, and M. Noori, "Advancements in energy harvesting techniques for sustainable IoT devices," *Results in Engineering*, 2025, [doi: 10.1016/j.rineng.2025.104820](https://doi.org/10.1016/j.rineng.2025.104820).
- [13] G. Moloudian, M. Hosseinifard, S. Kumar, R. B. V. B. Simorangkir, J. L. Buckley, C. Song, G. Fantoni, and B. O'Flynn, "RF energy harvesting techniques for battery-less wireless sensing, Industry 4.0 and Internet of Things: A review," *IEEE Sensors Journal*, 2024, [doi: 10.1109/JSEN.2024.3352402](https://doi.org/10.1109/JSEN.2024.3352402).

- [14] S. Kim and R. Vyas, "Ambient RF energy-harvesting technologies for self-sustainable standalone wireless sensor platforms," *Proceedings of the IEEE*, 2014, doi: [10.1109/JPROC.2014.2357031](https://doi.org/10.1109/JPROC.2014.2357031).
- [15] A. O. Korotkevich, Z. S. Galochkina, O. Lavrova, and E. Coutsias, "On the comparison of energy sources: Feasibility of radio frequency and ambient light harvesting," *Renewable Energy*, vol. 81, pp. 804–807, Sep. 2015, doi: [10.1016/j.renene.2015.03.065](https://doi.org/10.1016/j.renene.2015.03.065).
- [16] A. Chatterjee *et al.*, "Powering internet-of-things from ambient energy: A review," *Journal of Physics: Energy*, vol. 5, no. 2, Art. no. 022001, 2023, doi: [10.1088/2515-7655/acb5e6](https://doi.org/10.1088/2515-7655/acb5e6).
- [17] D. Ma, G. Lan, M. Hassan, W. Hu, and S. K. Das, "Sensing, computing, and communications for energy harvesting IoTs: A survey," *IEEE Communications Surveys and Tutorials*, vol. 22, no. 2, pp. 1222–1250, 2019, doi: [10.1109/COMST.2019.2962119](https://doi.org/10.1109/COMST.2019.2962119).
- [18] S. Ulukus *et al.*, "Energy harvesting wireless communications: A review of recent advances," *IEEE Journal on Selected Areas in Communications*, vol. 33, no. 3, pp. 360–381, Mar. 2015, doi: [10.1109/JSAC.2015.2391531](https://doi.org/10.1109/JSAC.2015.2391531).
- [19] B. Safaei, M. Peiravian, and M. Siamaki, "Eco-Friendly IoT: Leveraging Energy Harvesting for a Sustainable Future," *IEEE Sensors Review*, vol. 2, pp. 32–75, 2025, doi: [10.1109/SR.2025.3552043](https://doi.org/10.1109/SR.2025.3552043).
- [20] J. Curry and N. Harris, "Powering the Environmental Internet of Things: A Review," *Sensors*, vol. 19, no. 9, Art. no. 1947, 2019, doi: [10.3390/s19091947](https://doi.org/10.3390/s19091947).
- [21] M. Shirvan Moghaddam, Y. Li, B. Shi, Z. Li, and Z. L. Wang, "Towards a Green and Self-Powered Internet of Things Using Piezoelectric Energy Harvesting," *IEEE Access*, vol. 7, pp. 94533–94556, 2019, doi: [10.1109/ACCESS.2019.2927004](https://doi.org/10.1109/ACCESS.2019.2927004).
- [22] Q. Shi and H. Liu, "Special issue on energy harvesters and self-powered sensors for smart electronics," *Micromachines*, vol. 12, art. no. 1455, 2021, doi: [10.3390/mi12121455](https://doi.org/10.3390/mi12121455).
- [23] T. Sanislav, S. Zeadally, G. D. Mois, and S. C. Folea, "Energy harvesting techniques for Internet of Things (IoT)," *IEEE Access*, 2021, doi: [10.1109/ACCESS.2021.3064066](https://doi.org/10.1109/ACCESS.2021.3064066).
- [24] V. Gogolou, T. Noulis, and V. F. Pavlidis, "Multi-source energy harvesting systems integrated in silicon: A comprehensive review," *Electronics*, vol. 14, art. no. 1951, 2025, doi: [10.3390/electronics14101951](https://doi.org/10.3390/electronics14101951).
- [25] S. Singh, "Environmental energy harvesting techniques to power standalone IoT-equipped sensor and its application in 5G communication," *Emerging Science Journal*, vol. 4, special issue, 2021, doi: [10.28991/esj-2021-SP1-08](https://doi.org/10.28991/esj-2021-SP1-08).
- [26] S. Kalaivani, C. Tharini, and S. V. Anand, "Design and analysis of an innovative energy harvesting solution for IoT sensor node deployment," *Journal of Nano- and Electronic Physics*, 2020, doi: [10.21272/jnep.16\(5\).05015](https://doi.org/10.21272/jnep.16(5).05015).
- [27] S. R. Anton and H. A. Sodano, "A review of power harvesting using piezoelectric materials (2003–2006)," *Smart Materials and Structures*, vol. 16, no. 3, 2007, doi: [10.1088/0964-1726/16/3/R01](https://doi.org/10.1088/0964-1726/16/3/R01).
- [28] H. Shaukat, A. Ali, S. Ali, W. A. Altabey, M. Noori, and S. A. Kouritem, "Applications of sustainable hybrid energy harvesting: A review," *Journal of Low Power Electronics and Applications*, vol. 13, no. 2, art. no. 62, 2023, doi: [10.3390/jlpea13040062](https://doi.org/10.3390/jlpea13040062).
- [29] A. Aripriharta, A. Firmansah, M. Yazid, I. D. Wahyono, Muladi, and G. J. Horng, "Modelling of adaptive power management circuit with feedback for self-powered IoT," *Journal of Physics: Conference Series*, vol. 1595, p. 012023, 2020. doi: [10.1088/1742-6596/1595/1/012023](https://doi.org/10.1088/1742-6596/1595/1/012023).
- [30] H. Liu, H. Fu, L. Sun, C. Lee, and E. M. Yeatman, "Hybrid energy harvesting technology: From materials, structural design, system integration to applications," *Renewable and Sustainable Energy Reviews*, vol. 134, p. 110473, 2020, doi: [10.1016/j.rser.2020.110473](https://doi.org/10.1016/j.rser.2020.110473).
- [31] S. Naifar, O. Kanoun, C. Trigona, "Energy Harvesting Technologies and Applications for the Internet of Things and Wireless Sensor Networks". *Sensors* 2024, 24, 4688, doi: [10.3390/s24144688](https://doi.org/10.3390/s24144688)
- [32] O. Kanoun, S. Bradai, S. Khriji, G. Bouattour, D. Houssaini, M. Ben Ammar, A. Bouhamed, F. Derbel, C. Viehweger, Energy-Aware System Design for Autonomous Wireless Sensor Nodes: A Comprehensive Review, *Sensors* 2021, 21, 548, doi: [10.3390/s21020548](https://doi.org/10.3390/s21020548)
- [33] M. Lanuzza, R. De Rose, S. Strangio, Design of Ultra-Low Voltage/Power Circuits and Systems. *Electronics* 2022, 11, 607, doi: [10.3390/electronics11040607](https://doi.org/10.3390/electronics11040607)
- [34] Babu, M., (2025). Integrated Power Consumption Modeling for Low-Power Electronic Design. *Poornaprajna International Journal of Basic & Applied Sciences (PIJBAS)*, 90-99, doi: [10.5281/zenodo.18598155](https://doi.org/10.5281/zenodo.18598155)
- [35] V. Jain, S. Ghosh, G. Srilakshmi, N. V. A. Bhavani, A. Chezhan, and R. Nayak, "Sustainable energy harvesting in IoT devices: A review of piezoelectric and triboelectric nanogenerators," *Journal of Information Systems Engineering and Management*, vol. 10, no. 39s, 2025.

- [36] T. T. K. Tuoi, N. V. Toan, and T. Ono, “Thermal energy harvester using ambient temperature fluctuations for self-powered wireless IoT sensing systems: A review,” *Nano Energy*, 2023, [doi: 10.1016/j.nanoen.2023.109186](https://doi.org/10.1016/j.nanoen.2023.109186).
- [37] S. K. Gawali and M. K. Deshmukh, “Energy autonomy in IoT technologies,” in *Proceedings of the 5th International Conference on Power and Energy Systems Engineering (CPESE)*, Nagoya, Japan, Sep. 19–21, 2018, [doi: 10.1016/j.egypro.2018.11.132](https://doi.org/10.1016/j.egypro.2018.11.132).
- [38] Calautit, K. Nasir, D. S. N. M., & Hughes, B. R. (2021). Low power energy harvesting systems: state of the art and future challenges. *Renewable and Sustainable Energy Reviews*, 147, [doi:10.1016/j.rser.2021.111230](https://doi.org/10.1016/j.rser.2021.111230)
- [39] W. K. G. Seah, Y. K. Tan, and A. T. S. Chan, “Research in energy harvesting wireless sensor networks and the challenges ahead.”
- [40] S. Gómez-Gijón, F. J. Romero, V. Toral, and A. Rivadeneyra, “Energy harvesting for sustainable electronics: Challenges and opportunities,” *MRS Communications*, vol. 16, pp. 155–166, 2026, [doi: 10.1557/s43579-025-00892-w](https://doi.org/10.1557/s43579-025-00892-w).